

## Overvoltage Protection for 2-Series and 3-Series Cell Li-Ion Batteries

 Check for Samples: [bq294502](#), [bq294504](#), [bq294512](#), [bq294522](#), [bq294582](#), [bq294592](#)

### FEATURES

- 2-Series and 3-Series Cell Monitor for Secondary Protection
- Fixed Programmable Delay Timer
- Fixed OVP Threshold:
  - bq294502 = 4.35 V with 4-s Delay Timer
  - bq294504 = 4.35 V with 6.5-s Delay Timer
  - bq294512 = 4.40 V with 4-s Delay Timer
  - bq294522 = 4.45 V with 4-s Delay Timer
  - bq294532 = 4.50 V with 4-s Delay Timer
  - bq294562 = 4.25 V with 4-s Delay Timer
  - bq294572 = 4.00 V with 4-s Delay Timer
  - bq294582 = 4.225 V with 4-s Delay Timer
  - bq294524 = 4.45 V with 6.5-s Delay Timer
  - bq294584 = 4.225 V with 6.5-s Delay Timer
  - bq294592 = 4.30 V with 4-s Delay Timer
- High-Accuracy Overvoltage Protection:
  - ± 10 mV

- Low Power Consumption  $I_{CC} \approx 1 \mu\text{A}$  ( $V_{CELL(ALL)} < V_{PROTECT}$ )
- Low leakage current per cell input < 100 nA
- Small package footprint
  - 6-pin SON

### APPLICATIONS

- 2<sup>nd</sup>-Level Protection in Li-Ion Battery Packs in:
  - Tablets
  - Slates
  - Power Tools
  - Notebook Computers
  - Portable Equipment and Instrumentation

### DESCRIPTION

The bq2945xy family of products is a secondary level voltage monitor and protector for Li-Ion battery pack systems. Each cell is monitored independently for an overvoltage condition. Based on the configuration, an output is triggered after a fixed delay if any one of the two or three cells has an overvoltage condition. This output will be triggered into a high state after an overvoltage condition has satisfied the specified delay timer.

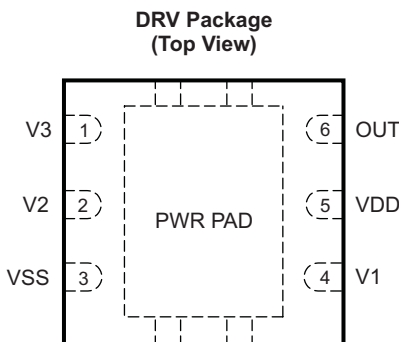

Please be aware that an important notice concerning availability, standard warranty, and use in critical applications of Texas Instruments semiconductor products and disclaimers thereto appears at the end of this data sheet.



These devices have limited built-in ESD protection. The leads should be shorted together or the device placed in conductive foam during storage or handling to prevent electrostatic damage to the MOS gates.

**ORDERING INFORMATION<sup>(1)</sup>**

T <sub>A</sub>	PART NUMBER	PACKAGE	PACKAGE DESIGNATOR	OVP (V)	DELAY TIME (S)	TAPE AND REEL (LARGE)	TAPE AND REEL (SMALL)
-40°C to 110°C	bq294502	SON-6	DRV	4.35	4.0	bq294502DRVR	bq294502DRVT
	bq294504			4.35	6.5	bq294504DRVR	bq294504DRVT
	bq294512			4.40	4.0	bq294512DRVR	bq294512DRVT
	bq294522			4.45	4.0	bq294522DRVR	bq294522DRVT
	bq294532 <sup>(2)</sup>			4.50	4.0	bq294532DRVR	bq294532DRVT
	bq294562			4.25	4.0	bq294562DRVR	bq294562DRVT
	bq294572 <sup>(2)</sup>			4.00	4.0	bq294572DRVR	bq294572DRVT
	bq294582			4.225	4.0	bq294582DRVR	bq294582DRVT
	bq294524 <sup>(2)</sup>			4.45	6.5	bq294524DRVR	bq294524DRVT
	bq294584 <sup>(2)</sup>			4.225	6.5	bq294584DRVR	bq294584DRVT
	bq294592			4.30	4.0	bq294592DRVR	bq294592DRVT

- (1) For the most current package and ordering information, see the Package Option Addendum at the end of this document, or visit the device product folder on ti.com ([www.ti.com](http://www.ti.com)).
- (2) Product Preview only

**THERMAL INFORMATION**

THERMAL METRIC <sup>(1)</sup>		bq2945xy	UNITS
		SON	
		6 PINS	
θ <sub>JA</sub>	Junction-to-ambient thermal resistance	186.4	°C/W
θ <sub>JC(top)</sub>	Junction-to-case(top) thermal resistance	90.4	
θ <sub>JB</sub>	Junction-to-board thermal resistance	110.7	
ψ <sub>JT</sub>	Junction-to-top characterization parameter	96.7	
ψ <sub>JB</sub>	Junction-to-board characterization parameter	90	
θ <sub>JC(bottom)</sub>	Junction-to-case(bottom) thermal resistance	n/a	

- (1) For more information about traditional and new thermal metrics, see the *IC Package Thermal Metrics* application report, [SPRA953](#).

## PIN FUNCTIONS

bq2945xy	Pin Name	Type I/O	Description
1	V3	IA	Sense input for positive voltage of the third cell from the bottom of the stack
2	V2	IA	Sense input for positive voltage of the second cell from the bottom of the stack
3	VSS	P	Electrically connected to IC ground and negative terminal of the lowest cell in the stack
4	V1	IA	Sense input for positive voltage of the lowest cell in the stack
5	VDD	P	Power supply
6	OUT	OA	Output drive for external N-Channel FET
Thermal Pad	PWRPAD	—	VSS pin to be connected to the PWRPAD on the printed circuit board for proper operation

## PIN DETAILS

### Description

The voltage sensing for each cell is done independently using a multiplexer. The method of overvoltage detection is comparing the voltage to an overvoltage protection voltage  $V_{OV}$ . Once the voltage exceeds the programmed fixed value, the delay timer circuit is activated. This delay ( $t_{DELAY}$ ) is fixed for either a 4-s or 6.5-s delay. When these conditions are satisfied, the OUT terminal is transitioned to a high level. This output (OUT) is released to a low condition if *all* of the cell inputs ( $V_x$ ) are below the OVP threshold minus the  $V_{hys}$ .



**Figure 1. Timing for Overvoltage Sensing**

### Sense Positive Input for $V_x$

This is an input to sense each single battery cell voltage. A series resistor and a capacitor across the cell for each input is required for noise filtering and stable voltage monitoring.

### Output Drive, OUT

The gate of an external N-Channel MOSFET is connected to this terminal. This output transitions to a high level when an overvoltage condition is detected and after the programmed delay timer. The out will reset to a low level if the cell voltage falls below the  $V_{OV}$  threshold before the fixed delay timer expires.

### Supply Input, VDD

This terminal is the unregulated input power source for the IC. A series resistor is connected to limit the current, and a capacitor is connected to ground for noise filtering.

**Thermal Pad, PWRPAD**

For correct operation, the power pad (PWRPAD) is connected to the V<sub>SS</sub> terminal on the printed circuit board.

**FUNCTIONAL BLOCK DIAGRAM**

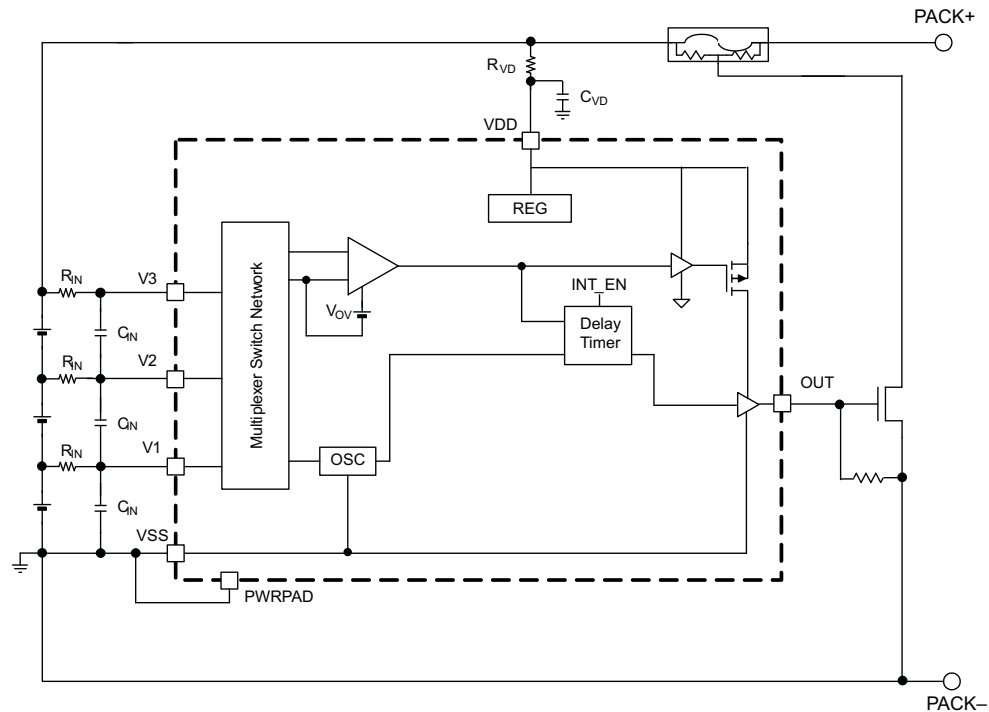

**ABSOLUTE MAXIMUM RATINGS**

Over operating free-air temperature range (unless otherwise noted)<sup>(1)</sup>

PARAMETER	CONDITION	VALUE/UNIT
Supply voltage range	VDD–VSS	–0.3 to 30 V
Input voltage range	V1–VSS or V2–VSS or V3–VSS	–0.3 to 30 V
	V3–V2 or V2–V1	–0.3 to 8 V
Output voltage range	OUT–VSS	–0.3 to 30 V
Continuous total power dissipation, P <sub>TOT</sub>		See package dissipation rating.
Functional temperature		–65 to 110°C
Storage temperature range, T <sub>STG</sub>		–65 to 150°C
Lead temperature (soldering, 10 s), T <sub>SOLDER</sub>		300°C

(1) Stresses beyond those listed under “absolute maximum ratings” may cause permanent damage to the device. These are stress ratings only and functional operation of the device at these or any other conditions beyond those indicated under “recommended operating conditions” is not implied. Exposure to absolute-maximum-rated conditions for extended periods may affect device reliability.

**RECOMMENDED OPERATING CONDITIONS**

Over operating free-air temperature range (unless otherwise noted)

PARAMETER	MIN	NOM	MAX	UNIT
Supply voltage, V <sub>DD</sub> <sup>(1)</sup>	3		25	V
Input voltage range	V3–V2 or V2–V1 or V1–VSS			5
Operating ambient temperature range, T <sub>A</sub>	–40		110	°C

(1) See [APPLICATION SCHEMATIC](#).

## DC CHARACTERISTICS

Typical values stated where  $T_A = 25^\circ\text{C}$  and  $V_{DD} = 10.8\text{ V}$ , MIN/MAX values stated where  $T_A = -40^\circ\text{C}$  to  $110^\circ\text{C}$  and  $V_{DD} = 3\text{ V}$  to  $15\text{ V}$  (unless otherwise noted).

	Symbol	Parameter	Condition	Min	Typ	Max	Unit
<b>Voltage Protection Threshold VCx</b>							
1.0	$V_{OV}$	$V_{(PROTECT)} -$ Overvoltage Detection	bq294502, fixed delay 4 s		4.35		V
1.1			bq294504, fixed delay 6.5 s		4.35		V
1.2			bq294512, fixed delay 4 s		4.40		V
1.3			bq294522, fixed delay 4 s		4.45		V
1.4			bq294524, fixed delay 6.5 s <sup>(1)</sup>		4.45		V
1.5			bq294532, fixed delay 4 s <sup>(1)</sup>		4.50		V
1.6			bq294562, fixed delay 4 s		4.25		V
1.7			bq294572, fixed delay 4 s <sup>(1)</sup>		4.00		V
1.8			bq294582, fixed delay 4 s		4.225		V
1.9			bq294584, fixed delay 6.5 s <sup>(1)</sup>		4.225		V
1.10			bq294592, fixed delay 4 s		4.30		V
1.11	$V_{HYS}$	Overvoltage Detection Hysteresis		250	300	400	V
1.12	$V_{OA}$	OV Detection Accuracy	$T_A = 25^\circ\text{C}$	-10		10	mV
1.13	$V_{OA-DRIFT}$	OV Detection Accuracy due to Temperature	$T_A = -40^\circ\text{C}$ $T_A = 0^\circ\text{C}$ $T_A = 60^\circ\text{C}$ $T_A = 110^\circ\text{C}$	-40 -20 -24 -54		44 20 24 54	mV mV mV mV
<b>Supply and Leakage Current</b>							
1.14	$I_{CC}$	Supply Current	$(V3-V2) = (V2-V1) = (V1-VSS) = 4.0\text{ V}$ (See Figure 10 for reference)		1	2	$\mu\text{A}$
			$(V3-V2) = (V2-V1) = (V1-VSS) = 2.8\text{ V}$ with $T_A =$ $-40^\circ\text{C}$ to $60^\circ\text{C}$			1.25	
1.15	$I_{IN}$	Input Current at $V_x$ Pins	Measured at V3, V2, and V1 = 4.0 V $(V2-V1) = (V1-VSS) = 4.0\text{ V}$ $T_A = 0^\circ\text{C}$ to $60^\circ\text{C}$ (See Figure 10 for reference.)	-0.1		0.1	$\mu\text{A}$
<b>Output Drive OUT</b>							
1.16	$V_{OUT}$	Output Drive Voltage	$(V3-V2)$ or $(V2-V1)$ or $(V1-VSS) > V_{OV}$ $V_{DD} = 7.2\text{ V}$ , $I_{OH} = 100\text{ }\mu\text{A}$ , $T_A = -40^\circ\text{C}$ to $110^\circ\text{C}$	6			V
1.17			Two of the three cells are short circuit and only one cell is powered $(V3-V2)$ or $(V2-V1)$ or $(V1-VSS) > V_{OV}$ $V_{DD} = V_x$ (Cell voltage), $I_{OH} = 100\text{ }\mu\text{A}$ , $T_A = -40^\circ\text{C}$ to $110^\circ\text{C}$		$V_{DD} -$ 0.2		V
1.18			$(V3-V2)$ , $(V2-V1)$ , and $(V1-VSS) < V_{OV}$ , $I_{OL} = 100$ $\mu\text{A}$ , $T_A = 25^\circ\text{C}$ $T_A = -40^\circ\text{C}$ to $110^\circ\text{C}$		250	400	mV
1.19	$I_{OUT(Short)}$	OUT Short Circuit Current	$OUT = 0\text{ V}$ ( $V3-V2$ ) or $(V2-V1)$ or $(V1-VSS) > V_{OV}$			4.5	mA
1.20	$t_R$	Output Rise Time	$CL = 1\text{ nF}$ , $V_{OH(OUT)} = 0\text{ V}$ to $5\text{ V}$ <sup>(2)</sup>		5		$\mu\text{s}$
1.21	$Z_O$	Output Impedance			2	5	k $\Omega$
<b>Fixed Delay Timer</b>							
1.22	$t_{DELAY}$	Fault Detection Delay Time	Fixed Delay, bq2945x2	3.2	4	4.8	s
			Fixed Delay, bq2945x4	5.2	6.5	7.8	

(1) Product Preview only

(2) Specified by design. Not 100% tested in production.

### DC CHARACTERISTICS (continued)

Typical values stated where  $T_A = 25^\circ\text{C}$  and  $V_{DD} = 10.8\text{ V}$ , MIN/MAX values stated where  $T_A = -40^\circ\text{C}$  to  $110^\circ\text{C}$  and  $V_{DD} = 3\text{ V}$  to  $15\text{ V}$  (unless otherwise noted).

	Symbol	Parameter	Condition	Min	Typ	Max	Unit
<b>Voltage Protection Threshold VCx</b>							
1.23	$t_{\text{DELAY\_CTM}}$	Fault Detection Delay Time in Test Mode	Fixed delay (Internal settings)		15		ms

### TYPICAL CHARACTERISTICS

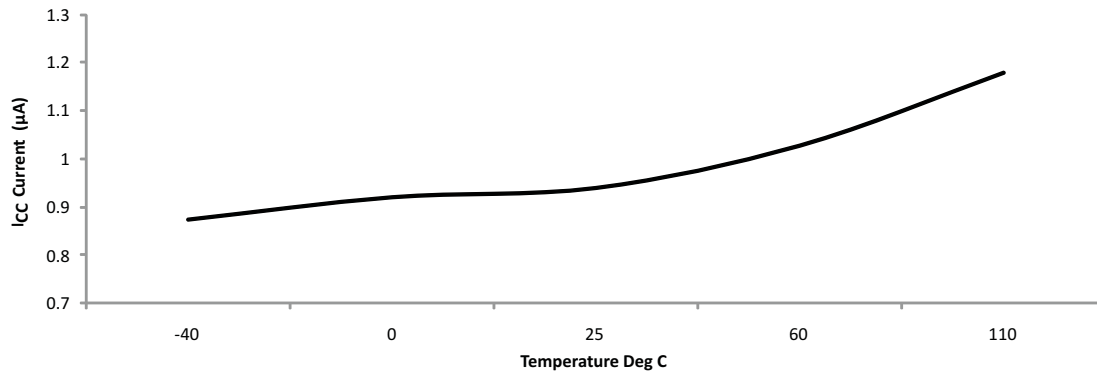

Figure 2. I<sub>CC</sub> Current Consumption Versus Temperature

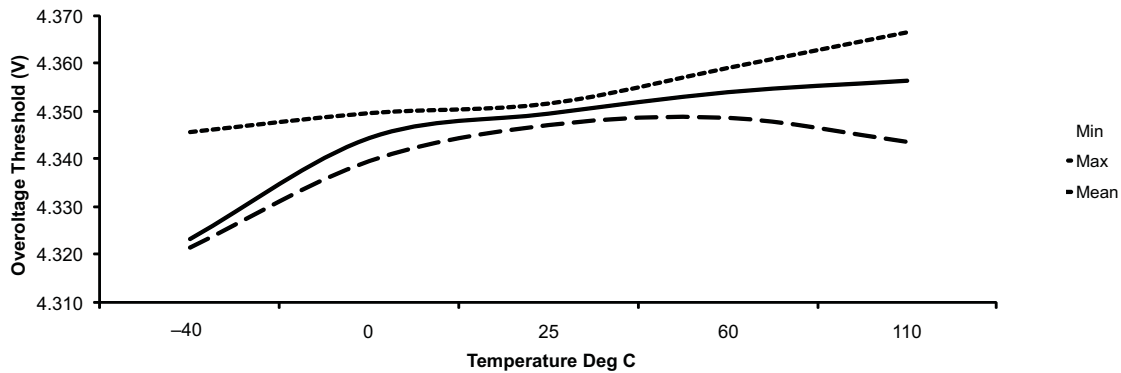

Figure 3. bq294502 Overvoltage Threshold (OVT) vs. Temp

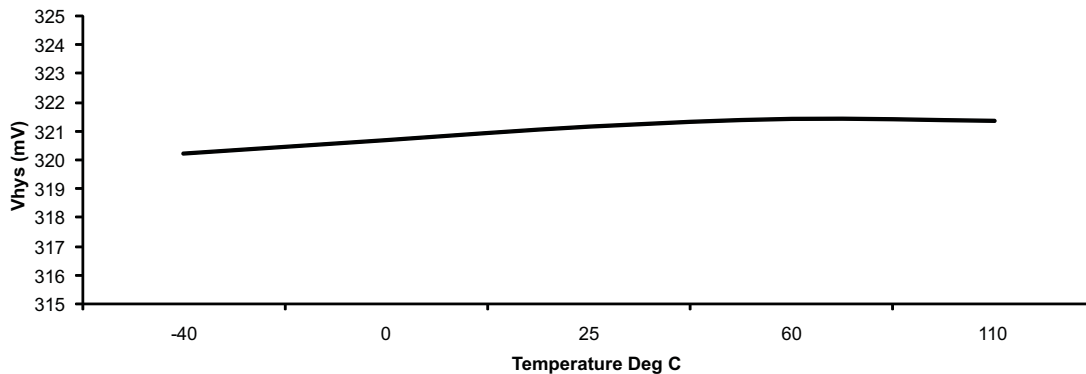

Figure 4. Hysteresis  $V_{HYS}$  Versus Temperature

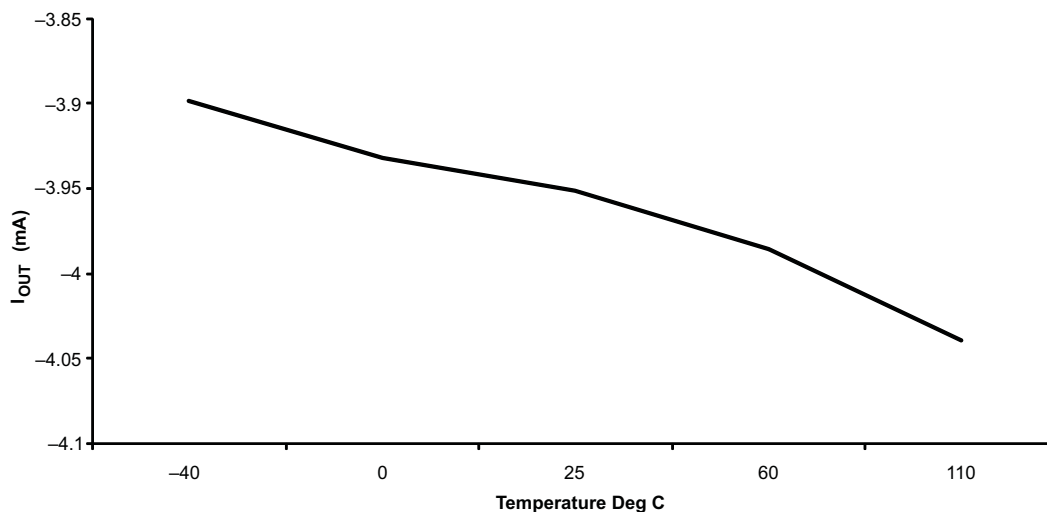
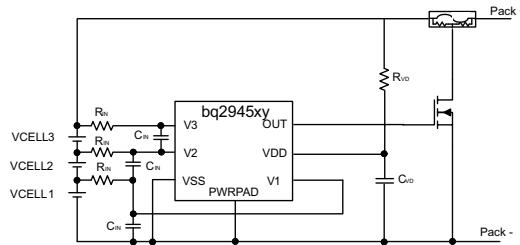

Figure 5. Output Current  $I_{OUT}$  Versus Temperature

**APPLICATION INFORMATION**



**Figure 6. Application Configuration**

Changes to the ranges stated in Table 1 will impact the accuracy of the cell measurements. Figure 6 shows each external component.

**Table 1. Parameters**

PARAMETER	External Component	MIN	NOM	MAX	UNIT
Voltage monitor filter resistance	RIN	900	1000	1100	Ω
Voltage monitor filter capacitance	CIN	0.01		0.1	μF
Supply voltage filter resistance	RVD	100		1K	Ω
Supply voltage filter capacitance	CVD		0.1		μF

**APPLICATION SCHEMATIC**

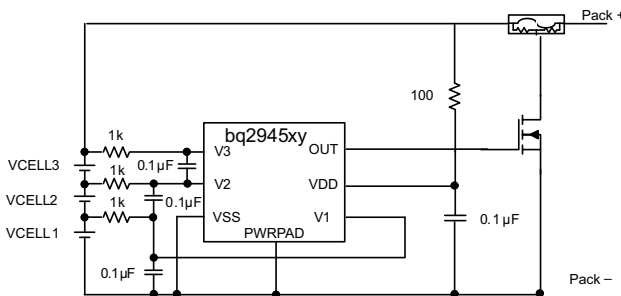

**Figure 7. 3-Series Cell Configuration with Fixed Delay**

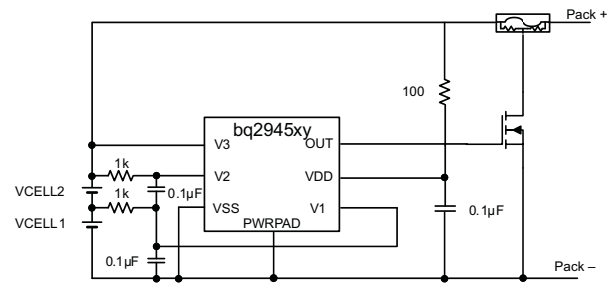

**Figure 8. 2-Series Cell Configuration with Internal Fixed Delay**

**CUSTOMER TEST MODE**

Customer Test Mode (CTM) helps to reduce test time for checking the overvoltage delay timer parameter once the circuit is implemented in the battery pack. To enter CTM, VDD should be set to at least 10 V higher than V3 (see Figure 9). The delay timer is greater than 10 ms, but considerably shorter than the timer delay in normal operation. To exit Customer Test Mode, remove the VDD to VC3 voltage differential of 10 V so that the decrease in this value automatically causes an exit.

**CAUTION**

Avoid exceeding any Absolute Maximum Voltages on any pins when placing the part into Customer Test Mode. Also avoid exceeding Absolute Maximum Voltages for the individual cell voltages (V3–V2), (V2–V1), and (V1–VSS). Stressing the pins beyond the rated limits may cause permanent damage to the device.

Figure 9 shows the timing for the Customer Test Mode.

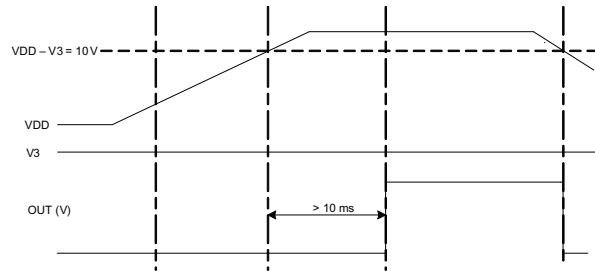

**Figure 9. Timing for Customer Test Mode**

Figure 10 shows the measurement for current consumption for the product for both VDD and Vx.

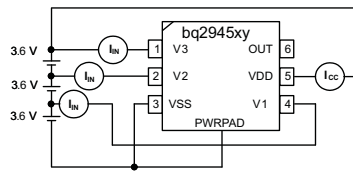

**Figure 10. Configuration for IC Current Consumption Test**

## REVISION HISTORY

---

Changes from Original (September 2011) to Revision A	Page
--	------

---

- Added the bq294582 Device to Production Data ..... 2
- 

Changes from Revision A (November 2011) to Revision B	Page
---	------

---

- Changed bq294504 Device to Production Data ..... 1
  - Added bq294512 Device ..... 1
  - Added bq294592 Device ..... 1
  - Added a second I<sub>CC</sub> Test Condition ..... 5
  - Changed Fault Detection Delay Time in bq2945x4 Test Mode Specifications ..... 5
-

**PACKAGING INFORMATION**

Orderable Device	Status <sup>(1)</sup>	Package Type	Package Drawing	Pins	Package Qty	Eco Plan <sup>(2)</sup>	Lead/ Ball Finish	MSL Peak Temp <sup>(3)</sup>	Samples (Requires Login)
BQ294502DRVR	ACTIVE	SON	DRV	6	3000	Green (RoHS & no Sb/Br)	CU NIPDAU	Level-2-260C-1 YEAR	
BQ294502DRVT	ACTIVE	SON	DRV	6	250	Green (RoHS & no Sb/Br)	CU NIPDAU	Level-2-260C-1 YEAR	
BQ294504DRVR	ACTIVE	SON	DRV	6	3000	Green (RoHS & no Sb/Br)	CU NIPDAU	Level-2-260C-1 YEAR	
BQ294504DRVT	ACTIVE	SON	DRV	6	250	Green (RoHS & no Sb/Br)	CU NIPDAU	Level-2-260C-1 YEAR	
BQ294512DRVR	ACTIVE	SON	DRV	6	3000	Green (RoHS & no Sb/Br)	CU NIPDAU	Level-2-260C-1 YEAR	
BQ294512DRVT	ACTIVE	SON	DRV	6	250	Green (RoHS & no Sb/Br)	CU NIPDAU	Level-2-260C-1 YEAR	
BQ294522DRVR	ACTIVE	SON	DRV	6	3000	Green (RoHS & no Sb/Br)	CU NIPDAU	Level-2-260C-1 YEAR	
BQ294522DRVT	ACTIVE	SON	DRV	6	250	Green (RoHS & no Sb/Br)	CU NIPDAU	Level-2-260C-1 YEAR	
BQ294582DRVR	ACTIVE	SON	DRV	6	3000	Green (RoHS & no Sb/Br)	CU NIPDAU	Level-2-260C-1 YEAR	
BQ294582DRVT	ACTIVE	SON	DRV	6	250	Green (RoHS & no Sb/Br)	CU NIPDAU	Level-2-260C-1 YEAR	
BQ294592DRVR	ACTIVE	SON	DRV	6	3000	Green (RoHS & no Sb/Br)	CU NIPDAU	Level-2-260C-1 YEAR	
BQ294592DRVT	ACTIVE	SON	DRV	6	250	Green (RoHS & no Sb/Br)	CU NIPDAU	Level-2-260C-1 YEAR	

<sup>(1)</sup> The marketing status values are defined as follows:

**ACTIVE:** Product device recommended for new designs.

**LIFEBUY:** TI has announced that the device will be discontinued, and a lifetime-buy period is in effect.

**NRND:** Not recommended for new designs. Device is in production to support existing customers, but TI does not recommend using this part in a new design.

**PREVIEW:** Device has been announced but is not in production. Samples may or may not be available.

**OBSELETE:** TI has discontinued the production of the device.

<sup>(2)</sup> Eco Plan - The planned eco-friendly classification: Pb-Free (RoHS), Pb-Free (RoHS Exempt), or Green (RoHS & no Sb/Br) - please check <http://www.ti.com/productcontent> for the latest availability information and additional product content details.

**TBD:** The Pb-Free/Green conversion plan has not been defined.

---

**Pb-Free (RoHS):** TI's terms "Lead-Free" or "Pb-Free" mean semiconductor products that are compatible with the current RoHS requirements for all 6 substances, including the requirement that lead not exceed 0.1% by weight in homogeneous materials. Where designed to be soldered at high temperatures, TI Pb-Free products are suitable for use in specified lead-free processes.

**Pb-Free (RoHS Exempt):** This component has a RoHS exemption for either 1) lead-based flip-chip solder bumps used between the die and package, or 2) lead-based die adhesive used between the die and leadframe. The component is otherwise considered Pb-Free (RoHS compatible) as defined above.

**Green (RoHS & no Sb/Br):** TI defines "Green" to mean Pb-Free (RoHS compatible), and free of Bromine (Br) and Antimony (Sb) based flame retardants (Br or Sb do not exceed 0.1% by weight in homogeneous material)

<sup>(3)</sup> MSL, Peak Temp. -- The Moisture Sensitivity Level rating according to the JEDEC industry standard classifications, and peak solder temperature.

**Important Information and Disclaimer:** The information provided on this page represents TI's knowledge and belief as of the date that it is provided. TI bases its knowledge and belief on information provided by third parties, and makes no representation or warranty as to the accuracy of such information. Efforts are underway to better integrate information from third parties. TI has taken and continues to take reasonable steps to provide representative and accurate information but may not have conducted destructive testing or chemical analysis on incoming materials and chemicals. TI and TI suppliers consider certain information to be proprietary, and thus CAS numbers and other limited information may not be available for release.

In no event shall TI's liability arising out of such information exceed the total purchase price of the TI part(s) at issue in this document sold by TI to Customer on an annual basis.

**TAPE AND REEL INFORMATION**

**REEL DIMENSIONS**

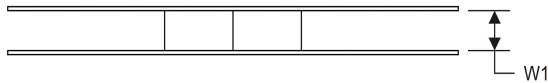
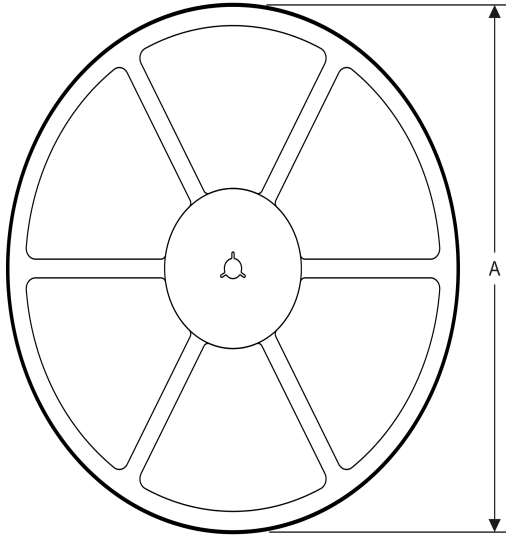

**TAPE DIMENSIONS**

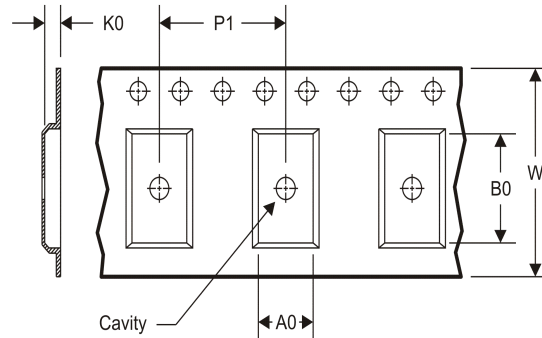

A0	Dimension designed to accommodate the component width
B0	Dimension designed to accommodate the component length
K0	Dimension designed to accommodate the component thickness
W	Overall width of the carrier tape
P1	Pitch between successive cavity centers

**TAPE AND REEL INFORMATION**

\*All dimensions are nominal

Device	Package Type	Package Drawing	Pins	SPQ	Reel Diameter (mm)	Reel Width W1 (mm)	A0 (mm)	B0 (mm)	K0 (mm)	P1 (mm)	W (mm)	Pin1 Quadrant
BQ294502DRVR	SON	DRV	6	3000	330.0	12.4	2.2	2.2	1.1	8.0	12.0	Q2
BQ294504DRVR	SON	DRV	6	3000	330.0	12.4	2.2	2.2	1.1	8.0	12.0	Q2
BQ294504DRVT	SON	DRV	6	250	180.0	12.4	2.2	2.2	1.1	8.0	12.0	Q2
BQ294512DRVR	SON	DRV	6	3000	330.0	12.4	2.2	2.2	1.1	8.0	12.0	Q2
BQ294512DRVT	SON	DRV	6	250	180.0	12.4	2.2	2.2	1.1	8.0	12.0	Q2
BQ294522DRVR	SON	DRV	6	3000	330.0	12.4	2.2	2.2	1.1	8.0	12.0	Q2
BQ294522DRVT	SON	DRV	6	250	180.0	12.4	2.2	2.2	1.1	8.0	12.0	Q2
BQ294582DRVR	SON	DRV	6	3000	330.0	12.4	2.2	2.2	1.1	8.0	12.0	Q2
BQ294582DRVT	SON	DRV	6	250	180.0	12.4	2.2	2.2	1.1	8.0	12.0	Q2
BQ294592DRVR	SON	DRV	6	3000	330.0	12.4	2.2	2.2	1.1	8.0	12.0	Q2
BQ294592DRVT	SON	DRV	6	250	180.0	12.4	2.2	2.2	1.1	8.0	12.0	Q2

**TAPE AND REEL BOX DIMENSIONS**

\*All dimensions are nominal

Device	Package Type	Package Drawing	Pins	SPQ	Length (mm)	Width (mm)	Height (mm)
BQ294502DRVR	SON	DRV	6	3000	346.0	346.0	29.0
BQ294504DRVR	SON	DRV	6	3000	346.0	346.0	29.0
BQ294504DRVT	SON	DRV	6	250	210.0	185.0	35.0
BQ294512DRVR	SON	DRV	6	3000	346.0	346.0	29.0
BQ294512DRVT	SON	DRV	6	250	210.0	185.0	35.0
BQ294522DRVR	SON	DRV	6	3000	346.0	346.0	29.0
BQ294522DRVT	SON	DRV	6	250	210.0	185.0	35.0
BQ294582DRVR	SON	DRV	6	3000	346.0	346.0	29.0
BQ294582DRVT	SON	DRV	6	250	210.0	185.0	35.0
BQ294592DRVR	SON	DRV	6	3000	346.0	346.0	29.0
BQ294592DRVT	SON	DRV	6	250	210.0	185.0	35.0

DRV (S-PWSON-N6)

PLASTIC SMALL OUTLINE NO-LEAD

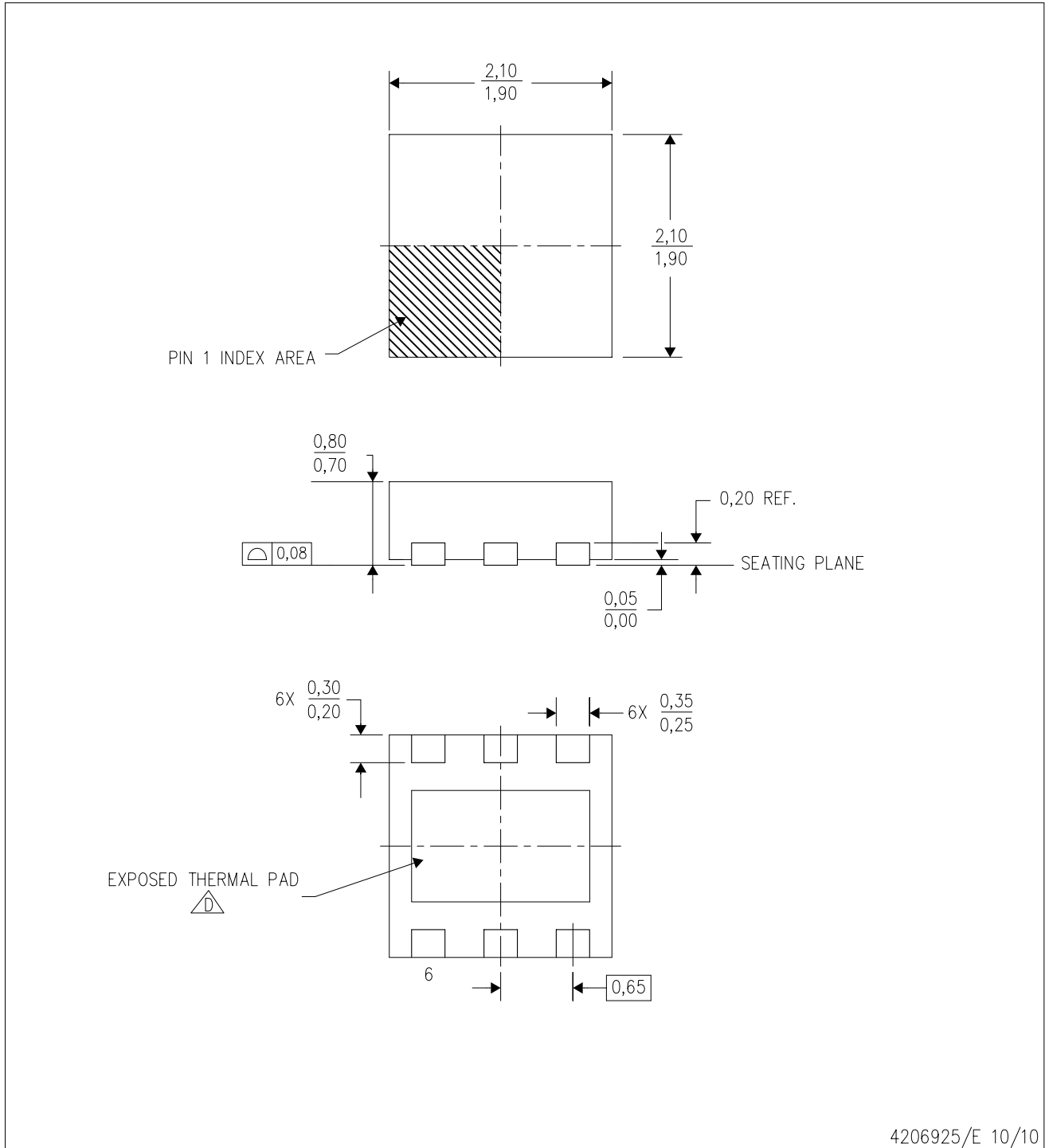

4206925/E 10/10

- NOTES:
- A. All linear dimensions are in millimeters. Dimensioning and tolerancing per ASME Y14.5M-1994.
  - B. This drawing is subject to change without notice.
  - C. Small Outline No-Lead (SON) package configuration.
  - D. The package thermal pad must be soldered to the board for thermal and mechanical performance. See the Product Data Sheet for details regarding the exposed thermal pad dimensions.

## THERMAL PAD MECHANICAL DATA

DRV (S-PWSON-N6)

PLASTIC SMALL OUTLINE NO-LEAD

### THERMAL INFORMATION

This package incorporates an exposed thermal pad that is designed to be attached directly to an external heatsink. The thermal pad must be soldered directly to the printed circuit board (PCB). After soldering, the PCB can be used as a heatsink. In addition, through the use of thermal vias, the thermal pad can be attached directly to the appropriate copper plane shown in the electrical schematic for the device, or alternatively, can be attached to a special heatsink structure designed into the PCB. This design optimizes the heat transfer from the integrated circuit (IC).

For information on the Quad Flatpack No-Lead (QFN) package and its advantages, refer to Application Report, QFN/SON PCB Attachment, Texas Instruments Literature No. SLUA271. This document is available at [www.ti.com](http://www.ti.com).

The exposed thermal pad dimensions for this package are shown in the following illustration.

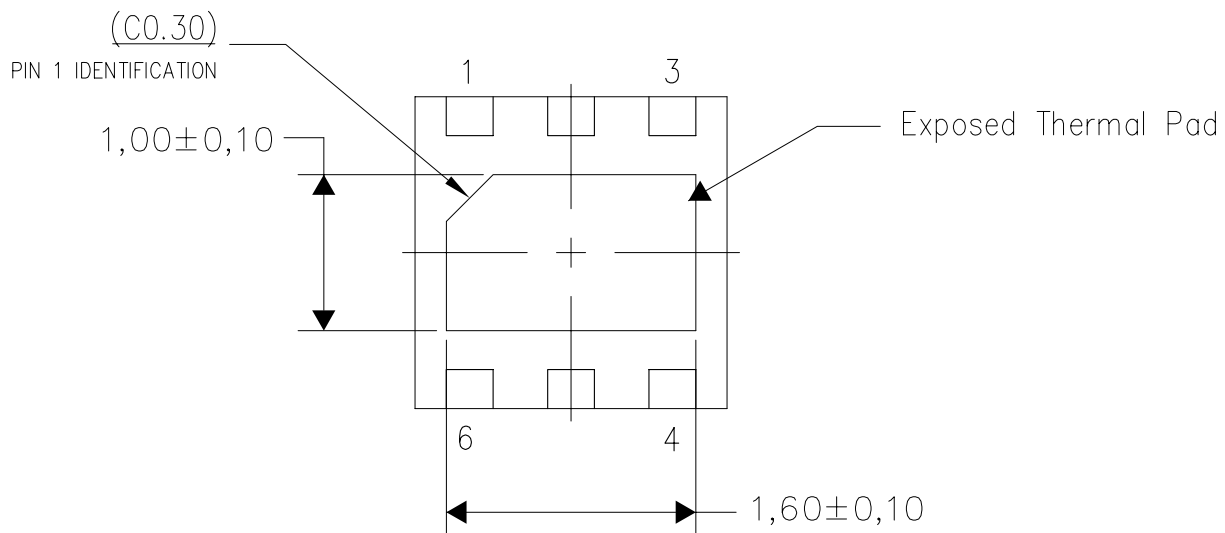

Bottom View

Exposed Thermal Pad Dimensions

4206926-2/L 11/11

NOTE: A. All linear dimensions are in millimeters

DRV (S-PWSON-N6)

PLASTIC SMALL OUTLINE NO-LEAD

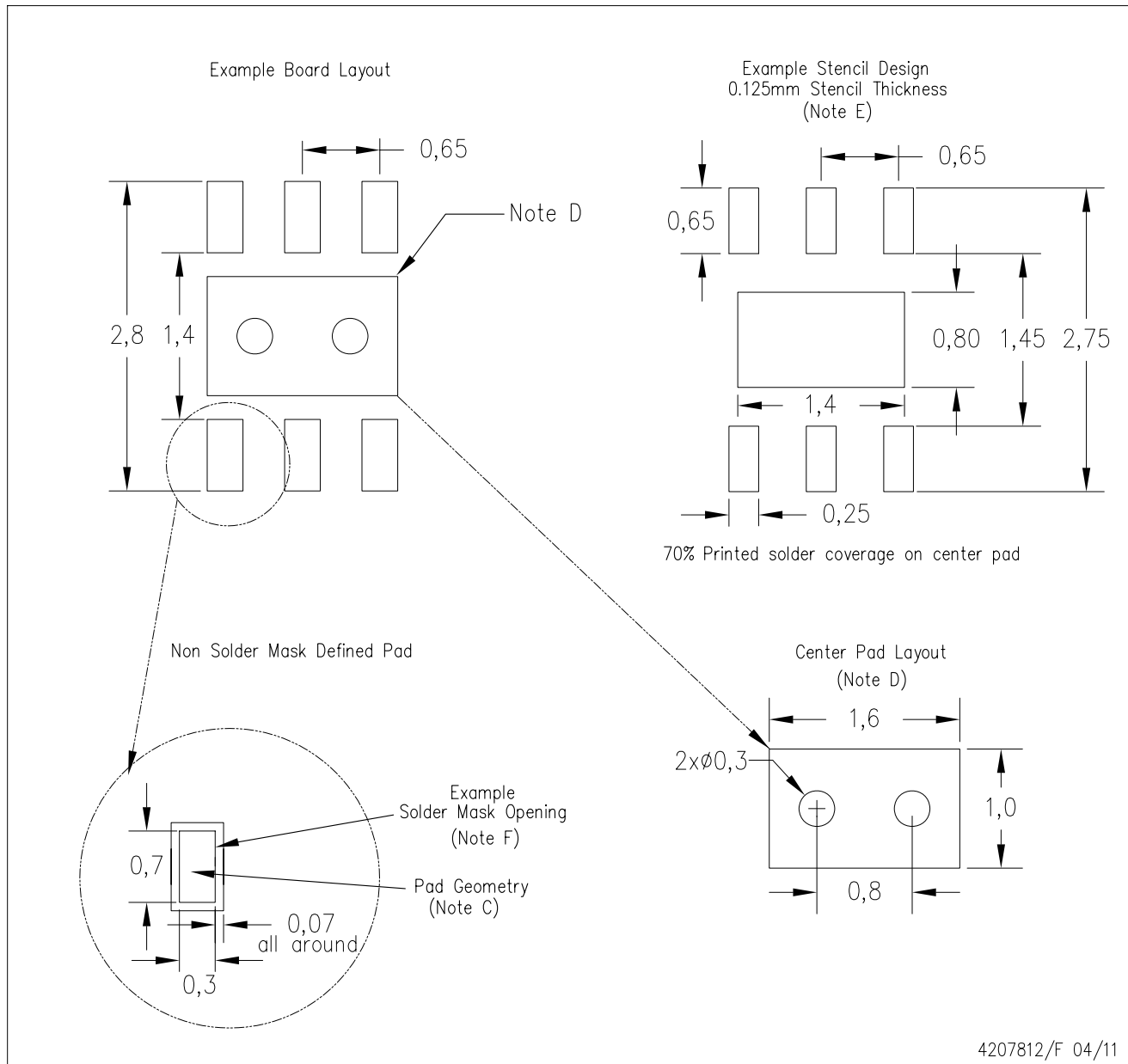

4207812/F 04/11

- NOTES:
- A. All linear dimensions are in millimeters.
  - B. This drawing is subject to change without notice.
  - C. Publication IPC-7351 is recommended for alternate designs.
  - D. This package is designed to be soldered to a thermal pad on the board. Refer to Application Note, QFN/SON PCB Attachment, Texas Instruments Literature No. SLUA271, and also the Product Data Sheets for specific thermal information, via requirements, and recommended board layout. These documents are available at [www.ti.com](http://www.ti.com) <<http://www.ti.com>>.
  - E. Laser cutting apertures with trapezoidal walls and also rounding corners will offer better paste release. Customers should contact their board assembly site for stencil design recommendations. Refer to IPC 7525 for stencil design considerations.
  - F. Customers should contact their board fabrication site for solder mask tolerances.

## IMPORTANT NOTICE

Texas Instruments Incorporated and its subsidiaries (TI) reserve the right to make corrections, modifications, enhancements, improvements, and other changes to its products and services at any time and to discontinue any product or service without notice. Customers should obtain the latest relevant information before placing orders and should verify that such information is current and complete. All products are sold subject to TI's terms and conditions of sale supplied at the time of order acknowledgment.

TI warrants performance of its hardware products to the specifications applicable at the time of sale in accordance with TI's standard warranty. Testing and other quality control techniques are used to the extent TI deems necessary to support this warranty. Except where mandated by government requirements, testing of all parameters of each product is not necessarily performed.

TI assumes no liability for applications assistance or customer product design. Customers are responsible for their products and applications using TI components. To minimize the risks associated with customer products and applications, customers should provide adequate design and operating safeguards.

TI does not warrant or represent that any license, either express or implied, is granted under any TI patent right, copyright, mask work right, or other TI intellectual property right relating to any combination, machine, or process in which TI products or services are used. Information published by TI regarding third-party products or services does not constitute a license from TI to use such products or services or a warranty or endorsement thereof. Use of such information may require a license from a third party under the patents or other intellectual property of the third party, or a license from TI under the patents or other intellectual property of TI.

Reproduction of TI information in TI data books or data sheets is permissible only if reproduction is without alteration and is accompanied by all associated warranties, conditions, limitations, and notices. Reproduction of this information with alteration is an unfair and deceptive business practice. TI is not responsible or liable for such altered documentation. Information of third parties may be subject to additional restrictions.

Resale of TI products or services with statements different from or beyond the parameters stated by TI for that product or service voids all express and any implied warranties for the associated TI product or service and is an unfair and deceptive business practice. TI is not responsible or liable for any such statements.

TI products are not authorized for use in safety-critical applications (such as life support) where a failure of the TI product would reasonably be expected to cause severe personal injury or death, unless officers of the parties have executed an agreement specifically governing such use. Buyers represent that they have all necessary expertise in the safety and regulatory ramifications of their applications, and acknowledge and agree that they are solely responsible for all legal, regulatory and safety-related requirements concerning their products and any use of TI products in such safety-critical applications, notwithstanding any applications-related information or support that may be provided by TI. Further, Buyers must fully indemnify TI and its representatives against any damages arising out of the use of TI products in such safety-critical applications.

TI products are neither designed nor intended for use in military/aerospace applications or environments unless the TI products are specifically designated by TI as military-grade or "enhanced plastic." Only products designated by TI as military-grade meet military specifications. Buyers acknowledge and agree that any such use of TI products which TI has not designated as military-grade is solely at the Buyer's risk, and that they are solely responsible for compliance with all legal and regulatory requirements in connection with such use.

TI products are neither designed nor intended for use in automotive applications or environments unless the specific TI products are designated by TI as compliant with ISO/TS 16949 requirements. Buyers acknowledge and agree that, if they use any non-designated products in automotive applications, TI will not be responsible for any failure to meet such requirements.

Following are URLs where you can obtain information on other Texas Instruments products and application solutions:

### Products

Audio	<a href="http://www.ti.com/audio">www.ti.com/audio</a>
Amplifiers	<a href="http://amplifier.ti.com">amplifier.ti.com</a>
Data Converters	<a href="http://dataconverter.ti.com">dataconverter.ti.com</a>
DLP® Products	<a href="http://www.dlp.com">www.dlp.com</a>
DSP	<a href="http://dsp.ti.com">dsp.ti.com</a>
Clocks and Timers	<a href="http://www.ti.com/clocks">www.ti.com/clocks</a>
Interface	<a href="http://interface.ti.com">interface.ti.com</a>
Logic	<a href="http://logic.ti.com">logic.ti.com</a>
Power Mgmt	<a href="http://power.ti.com">power.ti.com</a>
Microcontrollers	<a href="http://microcontroller.ti.com">microcontroller.ti.com</a>
RFID	<a href="http://www.ti-rfid.com">www.ti-rfid.com</a>
OMAP Mobile Processors	<a href="http://www.ti.com/omap">www.ti.com/omap</a>
Wireless Connectivity	<a href="http://www.ti.com/wirelessconnectivity">www.ti.com/wirelessconnectivity</a>

### Applications

Automotive and Transportation	<a href="http://www.ti.com/automotive">www.ti.com/automotive</a>
Communications and Telecom	<a href="http://www.ti.com/communications">www.ti.com/communications</a>
Computers and Peripherals	<a href="http://www.ti.com/computers">www.ti.com/computers</a>
Consumer Electronics	<a href="http://www.ti.com/consumer-apps">www.ti.com/consumer-apps</a>
Energy and Lighting	<a href="http://www.ti.com/energy">www.ti.com/energy</a>
Industrial	<a href="http://www.ti.com/industrial">www.ti.com/industrial</a>
Medical	<a href="http://www.ti.com/medical">www.ti.com/medical</a>
Security	<a href="http://www.ti.com/security">www.ti.com/security</a>
Space, Avionics and Defense	<a href="http://www.ti.com/space-avionics-defense">www.ti.com/space-avionics-defense</a>
Video and Imaging	<a href="http://www.ti.com/video">www.ti.com/video</a>

TI E2E Community Home Page

[e2e.ti.com](http://e2e.ti.com)

Mailing Address: Texas Instruments, Post Office Box 655303, Dallas, Texas 75265  
Copyright © 2012, Texas Instruments Incorporated